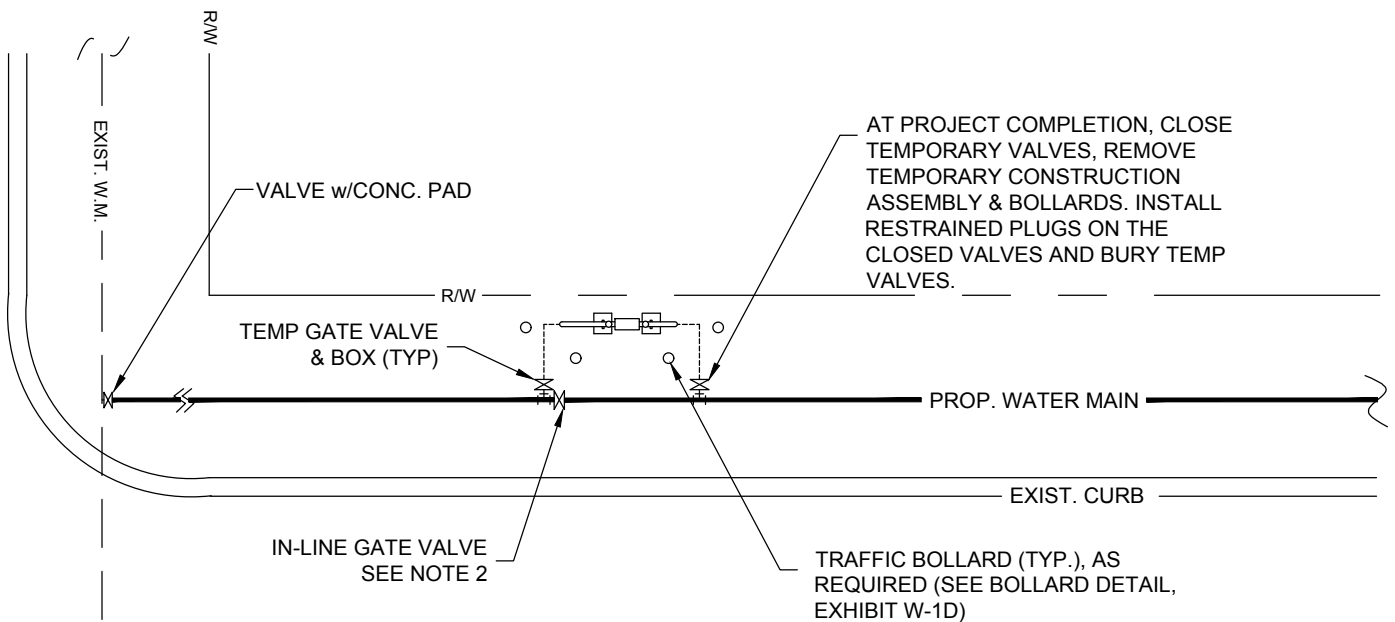
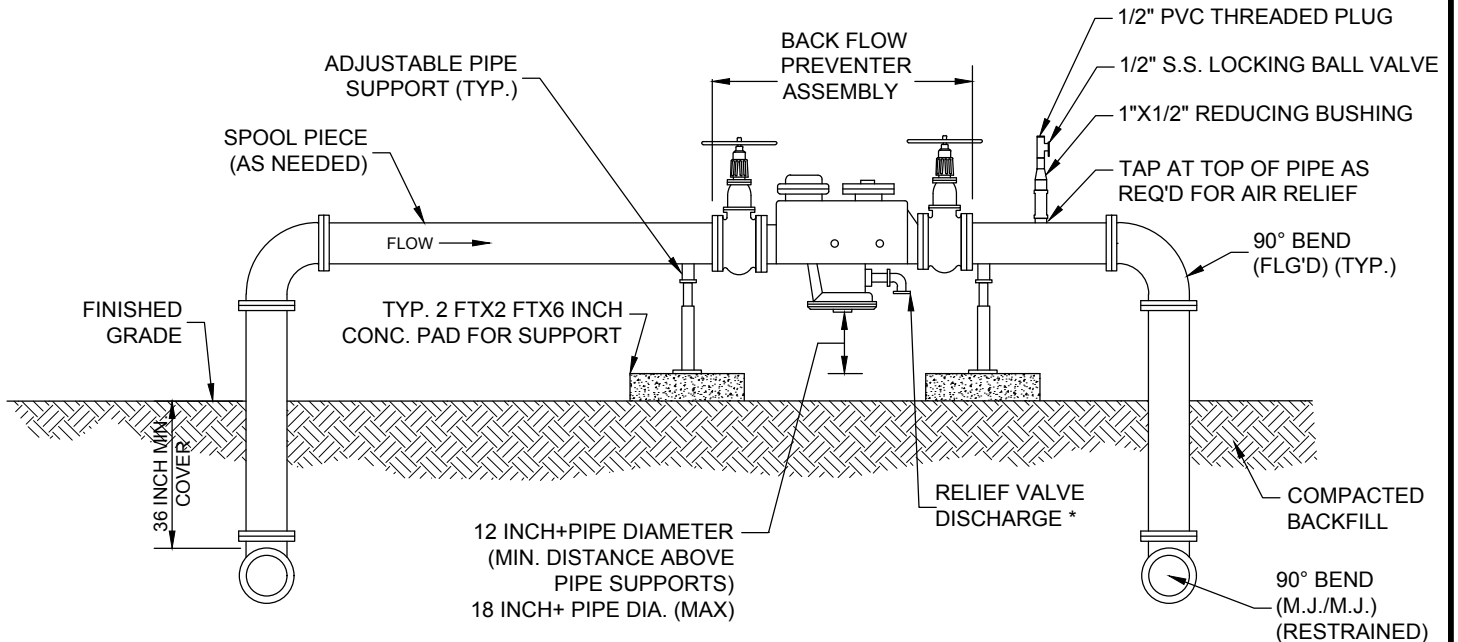

Exhibit No. W-1F



NOTES:

1. NO TAPS ON PIPING UPSTREAM OF THE BACKFLOW PREVENTER AND NO MODIFICATION OR USE OF BACKFLOW PREVENTER TEST PORTS FOR ANYTHING OTHER THAN TESTING.
2. AFTER REMOVAL OF THE TEMPORARY BACKFLOW ASSEMBLY, THE IN-LINE GATE VALVE SHALL HAVE A VALVE BOX, COVER, AND A 2'X2'X6" CONCRETE PAD INSTALLED (TYP.).

TEMPORARY CONSTRUCTION BACKFLOW ASSEMBLY
FOR RESIDENTIAL OR COMMERCIAL DEVELOPMENT 6" AND LARGER

3/2020

HILLSBOROUGH COUNTY, FLORIDA

SCALE: N.T.S.